

AN10832

PCF8883 - capacitive proximity switch with auto-calibration

Rev. 03 — 8 September 2010

Application note

Document information

Info	Content
Keywords	PCF8883; proximity switch; auto-calibration
Abstract	This application note describes briefly important factors for the usage of the PCF8883 sensor device.



Revision history

Rev	Date	Description
03	20100908	corrected revision
02	20100819	extended revision
01	20090612	new application note, first revision

Contact information

For more information, please visit: <http://www.nxp.com>

For sales office addresses, please send an email to: salesaddresses@nxp.com

1. Introduction

The PCF8883 IC is a capacitive switch that uses a patented digital technique (patent from Edisen) to detect a change of capacitance on the device input. In order to use this switch, the following must first be defined:

- the form and materials to be used
- the desired switching distance from the sensing plate and
- the desired switching characteristic

The following text explains the relationship between the product design and the electrical switching to be expected.

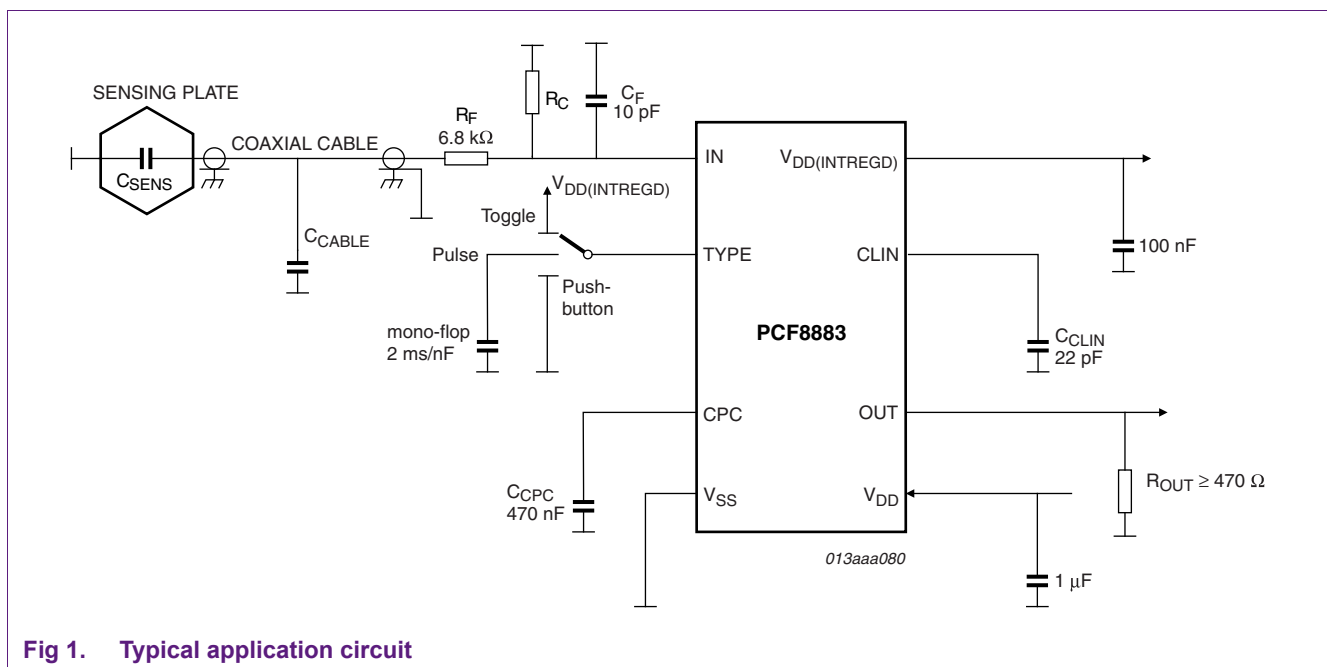

Fig 1. Typical application circuit

2. Dimensioning of R_C , C_{CPC} , and C_{CLIN}

The adaption of the switch to a particular application usually requires to adjust several components because certain parameters can be influenced by one or more factors: sensor area, sensor environment, and triggering must be taken into account. These aspects are constitutive for the behavior of the switch.

The circuit has three parameters that influence the switching behavior. Below they are listed in order of their influence:

- Switch sensitivity (C_{CPC} capacitance between CPC and V_{SS})
- Calibration of the total capacitance on the sensor input (R_C between IN and V_{SS})
- Switching speed (C_{CLIN} between CLIN and V_{SS})

Once the sensing area is defined (geometry, material, distance from sensing plate to input), the typical values given in the data sheet for C_{CPC} and C_{CLIN} should be used as a starting point for tuning the sensitivity of the switch.

2.1 R_C

This resistor must be used when the cable connecting the sensing plate to the input is longer than about 0.5 m or when the sensing plate area is larger than approximately the area of an adult hand; otherwise, no switching will happen.

According to the data sheet, the total capacitance on the input should be between 10 pF and 60 pF in order for the control loop to work correctly and reliably. In practice, it is normally impossible to measure this capacitance. Alternatively, the voltage on C_{CPC} can be measured. Ideally, the operating voltage on C_{CPC} should be $\frac{V_{DD(INTREGD)}}{2}$.

This measurement must be done with a high impedance probe ($R_{in} > 5 \text{ G}\Omega$) since this point has a high resistance¹. The lower limit for R_C is approximately 20 k Ω . It should be noted, that the IC has an internal 50 k Ω resistor connected in parallel to R_C (pin IN to V_{SS}). When R_C is less than 20 k Ω , higher internal currents are flowing and the precision of the device is declining.

Check the switching by touching the sensor plate although the final application will use proximity switching. Change the capacitance C_{CPC} if no switching occurs. Increasing the value of C_{CPC} should be tried first. If the sensor still does not switch, try simplifying the switch construction. In most cases, changing C_{CPC} will result in the sensor switching.

2.2 C_{CPC}

The sensitivity can be set once the sensor switches reliably (see previous step). Touching the sensor plate is the least critical case and usually works with the value of C_{CPC} given in the data sheet ($C_{CPC} = 470 \text{ nF}$, typical).

1. Measuring the voltage on the CPC capacitor is not usually possible since the impedance on pin CPC is too high for most oscilloscope probes. The problem can be solved by using a high impedance probe (a voltage follower for example).

Alternatively, it is possible to use the following characteristic of the PCF8883. On power-up, the internal capacitors are charged using 50 times the normal charging current in order to stabilize the control loop as quickly as possible. During this time, it is possible to measure the voltage at CPC correctly using a standard oscilloscope probe.

Adjustments are usually necessary when:

1. The sensor area is small and the triggering area is comparable or smaller. For example, if the sensor is used in a keyboard, the keys may have a small area. The area of a finger is comparable to the sensor area. The switch must be fine-tuned such that neighboring switches do not react.
2. The distance between the sensor plate and triggering object is larger than the sensor plate area (switching at a distance).
3. Switching through materials having different permittivity ϵ_r is desired.

The second point is actually a special case of the third point. The complexity is caused by the fact that the switching point is not solely defined by the sensing plate but also by the situation of the air (and its permittivity ϵ_r) between the plate and the triggering object. Since the nature of air can change slightly depending on conditions, the situation for proximity switching is not as well defined as when the plate has to be touched. This makes it difficult to give a precise range for switching at a distance. Furthermore, the sampling of the sensor influences switching at a distance as well (see [Section 2.3](#)). The cases listed above can also occur in combination.

A larger value of C_{CPC} increases the sensitivity, which means:

- That the sensor area can be reduced
- The sensor reacts at a distance
- The range through materials with different permittivity is increased

2.3 C_{CLIN}

C_{CLIN} defines the internal sampling frequency used to sample the signal on input pin IN. The sampling period is given by:

$$T(fk)[\mu s] = 300\mu s + C_{CLIN}[pF] \times 33\mu s/pF \quad (1)$$

The sensor reacts faster when the frequency is increased since the necessary number of comparisons is reached in less time. On the other hand, this also means that the sensor self calibrates to new environments more quickly with the result that a slow moving hand will no longer cause the sensor to switch: The sensor calibrates itself to the new environment (with the hand) more quickly than detecting the changes caused by the approaching hand. Another consequence of increasing the sampling frequency is that the sensor reacts to quick changes at a distance with higher sensitivity. This effect can be enhanced by increasing C_{CPC} or the sensing area.

To get the proper dimension of C_{CLIN} it is important to know the normal “approach speed” of the triggering object. A machine often moves more quickly than a human does; and a single finger could move more quickly than an entire hand.

It is also important to note that the power consumption of the device increases when increasing the sampling frequency.

3. Sensitivity and capacitance changes

Many factors can increase and decrease the sensitivity of the switch. The sensitivity is a function of:

- The approach speed of the triggering object
- The area of the sensor plate (or electrode) and the area of the triggering object
- The shape of the sensor plate and the triggering object
- The nature and thickness of the material between the electrodes
- The plate (or electrode) orientation
- The coupling between the sensor area, sensor triggering object, and the ground (earth)

The sensor area, the triggering object, and the dielectric material between them constitute a capacitor. The capacitance seen on the sensor input (IN) consists of all the desired capacitance and parasitic capacitance to be compensated by the control loop. In [Figure 2](#), the capacitor connected to the hand (triggering object) is used to show that a capacitance exists between the hand and ground (earth). The ground can be the negative supply or the earth, depending on the situation.

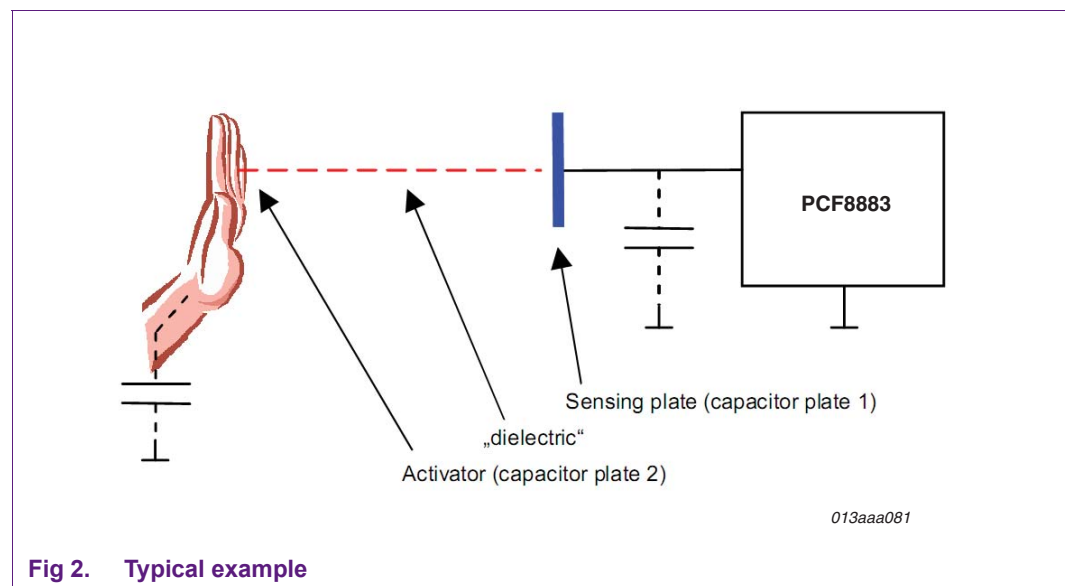

The capacitance of a plate capacitor is given by:

$$C = \frac{A}{d} \times \epsilon_0 \times \epsilon_r \quad (2)$$

Whereas

C = capacitance in F

A = cross sectional area of plates in m²

d = distance between sensing plate and activator in m

ϵ_0 = absolute permittivity of free space (8.85×10^{-12} F/m)

ϵ_r = relative permittivity of the material covering the sensor

This expression is valid for our example, but in practice, the plates are rarely identical and the distance and dielectric can change.

3.1 Capacitance changes

The voltage on the sensor input is compared to an internal reference at discrete points in time defined by the sampling frequency. The control loop continuously tries to maintain voltage equilibrium on C_{CPC} by either subtracting or adding charge to the capacitor. An up-down counter counts how often charge flows consecutively in one direction. In equilibrium, the counter is effectively continually reset since the charge flows first in one direction and then the other. The counter causes the output to switch when the counter has counted 63 times. The sensor reacts only to changes in capacitance. A finger that approaches the sensing plate continually changes the capacitance of the plate.

According to the capacitance equation above, the capacitance can also be changed by changing the area and the permittivity. In practice, the area and permittivity are more relevant for the sensitivity of the sensor.

4. Approach speed and dynamics

The sensor compensates changes in static or slowly changing capacitance. The sensor first switches when it can no longer compensate the change in capacitance.

Figure 3 shows how the capacitance changes with respect to the distance. The same capacitance change ΔC can be produced close to the sensing plate ($\Delta d1$) or further away ($\Delta d2$).

A triggering object moving at a constant speed will cause a larger capacitance change nearer to the plate than one further away from it.

Please note that the sensor requires more than 63 consecutive increases (or decreases) in capacitance over a fixed period to cause a switch; hence it can be deduced that the switch distance increases with increasing approach speeds.

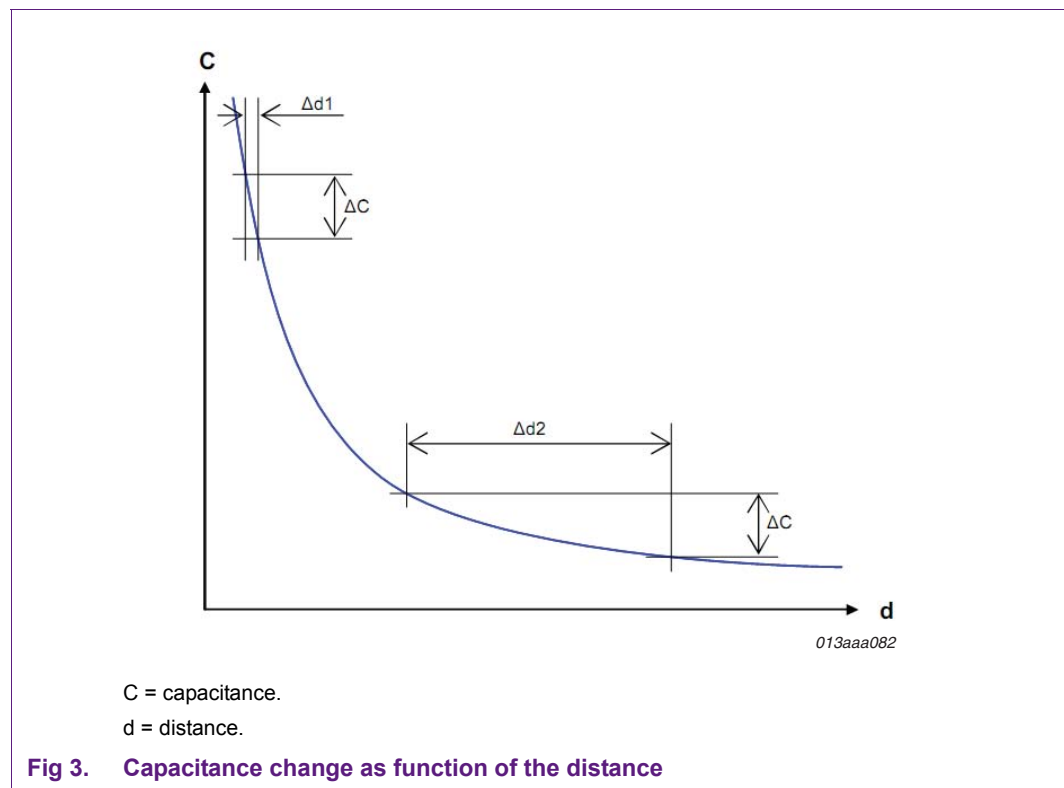

5. Influence of the size and form of the capacitor plates (electrodes)

An open input pin on PCF8883 represents the worst possible sensing area and is not recommended. The easiest method to increase the sensitivity is to increase the sensing area. The capacitance equation, [Equation 2](#), illustrates that the capacitance (C) is proportional to the cross sectional area of the sensing plate (A). In most cases, simply increasing the sensing area will lead to the desired result. When the sensing area is limited by the application then the value of C_{CPC} has to be increased to increase the sensitivity.

Increasing the size of the triggering object can also increase the sensitivity. Under certain conditions, this may be desired in order to optimize the switching characteristic for a particular application. For example, switching through a thick layer of material where the material itself influences the sensitivity (see [Figure 4](#)).

[Figure 4](#) shows, that despite a large sensor area a fingertip may be unable to make the sensor switch whereas the whole hand does it because it cuts all of the sensor's field lines. This simplified model can help to understand how to optimize the application.

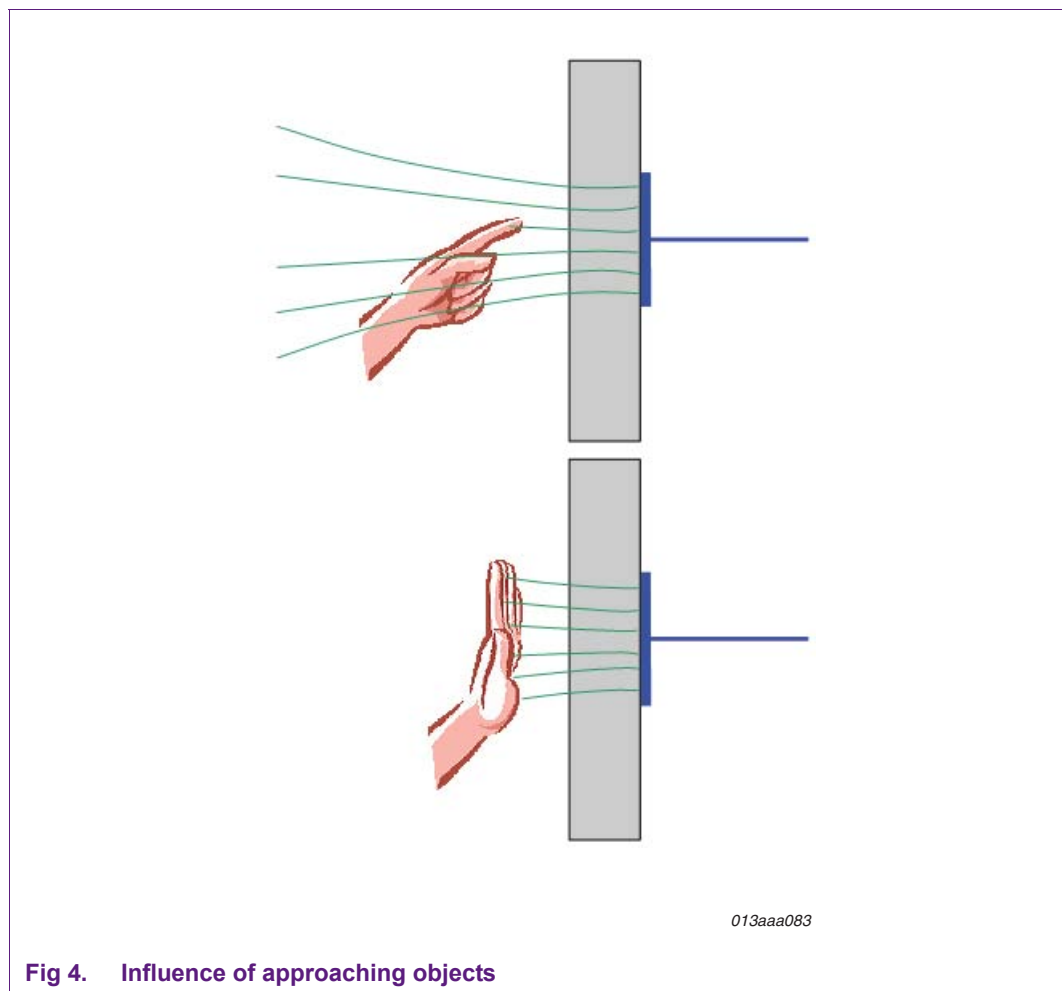

The minimal sensor area should not be smaller than the triggering object area. A larger sensing area is recommended. The sensor area or C_{CPC} must be increased in cases when switching has to take place through different layers (e.g. over distance, with differing permittivity).

Concerning the PCF8883, there is no limitation on form or design of the sensing area. The sensing area can take any form as long as the required sensitivity will be obtained. Oval or round areas are recommended, since they have the least edge effects.

6. Influence of thickness and nature of the dielectric

The dielectric encompasses everything between the sensing area and the triggering object area.

The thickness and nature of each dielectric influences the strength and flux of the electric field passing through. If different layers of material with different permittivity are used then all layers will influence the field and flux. The electric field will be refracted, diffracted, reflected and diminished depending on the exact materials and construction used. Another factor to be considered is the total thickness of the construction.

The range of permittivity ϵ_r for typical application materials are:

- Glass, ϵ_{rg} : 6 to 8
- Plastic, ϵ_{rp} : 2 to 4
- Conductive foam, ϵ_{rf} : 2 to 3
- Air, ϵ_{ra} : 1

6.1 Air gap

In the application shown in [Figure 5](#), the sensor area is mounted behind 10 mm glass, a 0.3 mm air gap and 2 mm plastic.

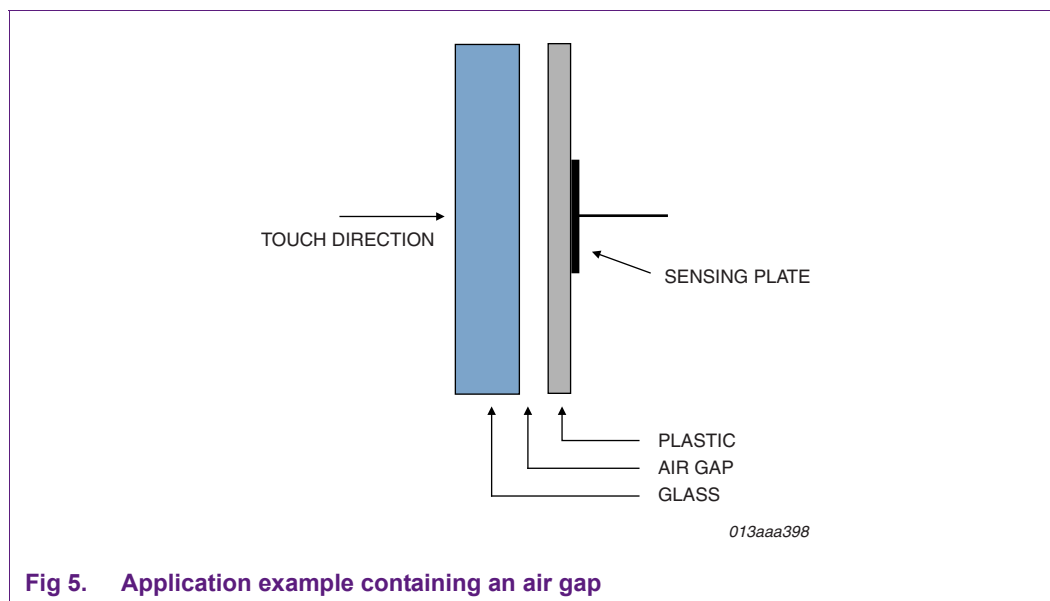

Materials having higher relative permittivity support higher sensitivity because the electrical field strength is proportional to the relative permittivity and inverse proportional to the thickness. The air gap above is an issue because the relative permittivity $\epsilon_r = 1$ is low compared to plastic or glass.

The sensitivity is proportional to the capacity value of C_{SENS} . The total capacity is composed of the capacitors of the materials in series:

- Glass: C_g
- Plastic: C_p

- Conductive foam: C_f
- Air: C_a

And d_x is the thickness of the materials.

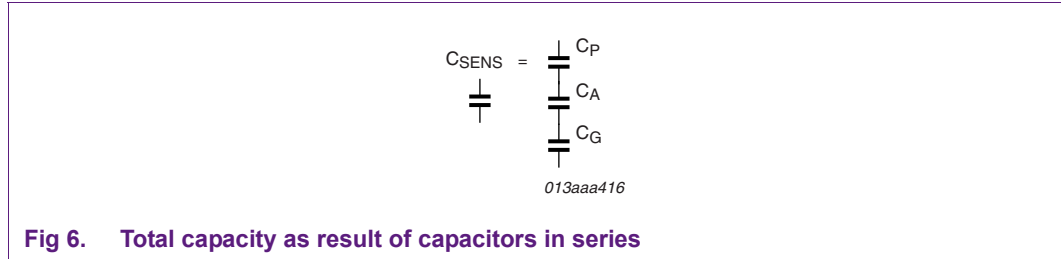

Fig 6. Total capacity as result of capacitors in series

$$C_p = \frac{A}{d_p} \times \epsilon_0 \times \epsilon_{rp} \tag{3}$$

$$C_a = \frac{A}{d_a} \times \epsilon_0 \times \epsilon_{ra} \tag{4}$$

$$C_g = \frac{A}{d_g} \times \epsilon_0 \times \epsilon_{rg} \tag{5}$$

Out of [Equation 3](#) to [Equation 5](#) C_{SENS} will be calculated with [Equation 6](#):

$$C_{SENS} = \frac{C_p \times C_a \times C_g}{C_p \times C_a + C_p \times C_g + C_a \times C_g} \tag{6}$$

The total capacity is smaller than the smallest of the three capacities. Therefore air gaps should be avoided or minimized and the thickness of the material should be reduced to a minimum.

6.2 Conductive foam

By placing some conductive foam between the sensor plate and the glass, an air gap can be avoided (see [Figure 7](#)).

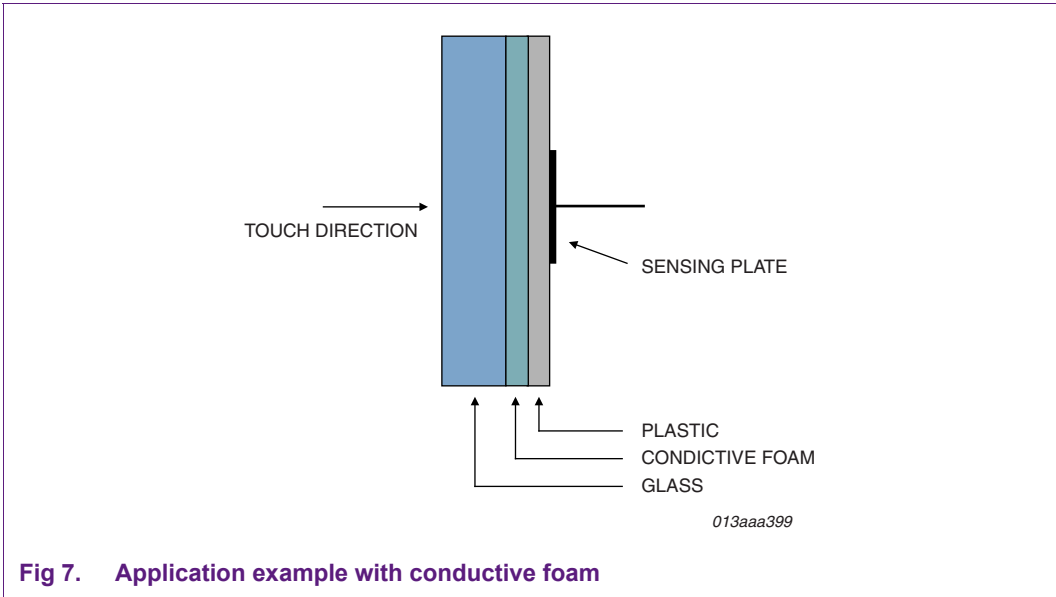

Fig 7. Application example with conductive foam
Compared with the example in [Section 6.1](#), replacing the air gap with conductive foam will increase the sensitivity of the set-up.

7. Plate (electrode) orientation

A capacitance change that is high enough will cause any application to switch. The following rule always applies:

The more field lines that the triggering object cuts, the larger the generated capacitance change will be.

[Figure 8](#) illustrates this effect. The approaching palm area triggers a switch faster than the side of the hand.

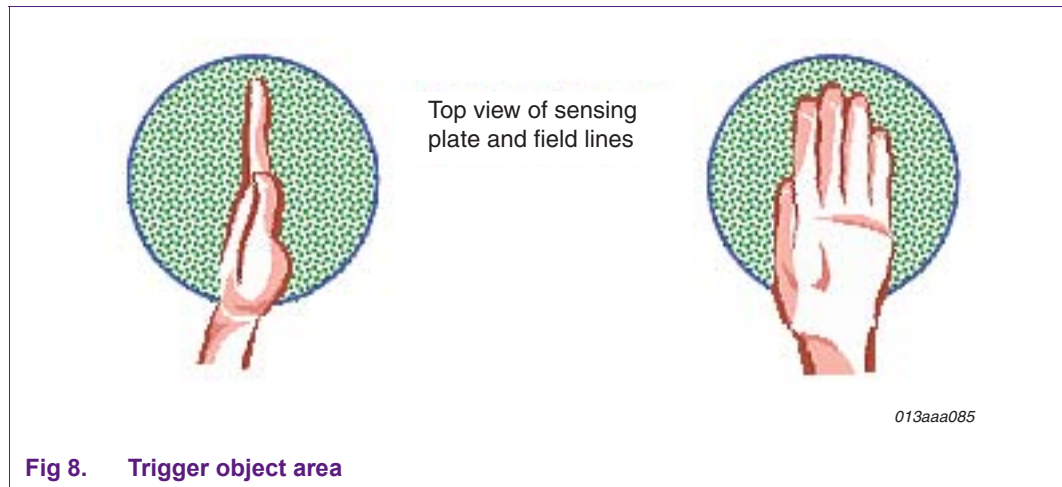

8. Electrical environment

The presence of ground (earth) influences capacitive sensing. [Figure 9](#) shows the expected field with and without neighboring grounds.

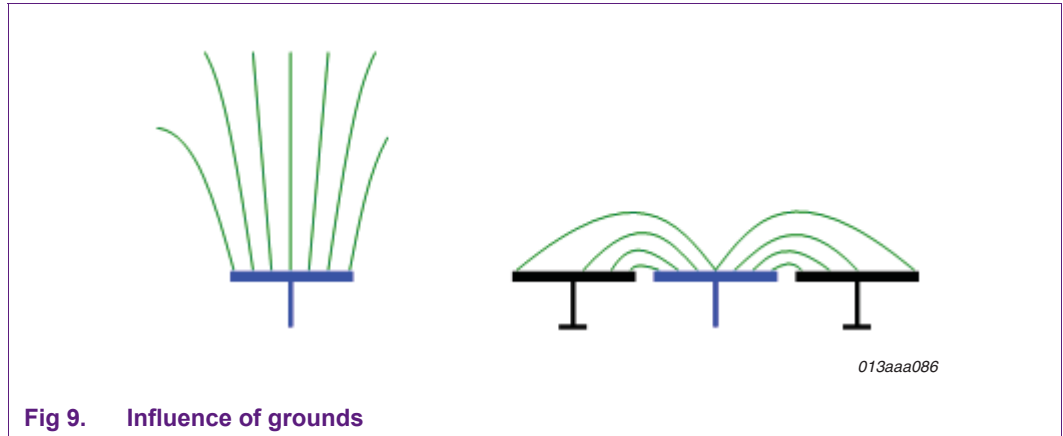

Fig 9. Influence of grounds

The electric field takes the shortest path to ground. As shown in [Figure 9](#), the presence of the ground flattens the field and therefore shortens the switching distance and sensitivity in comparison to the example without a ground nearby.

Conductors next to the sensor plate have either to be isolated by an air gap or by isolating material, see [Figure 10](#).

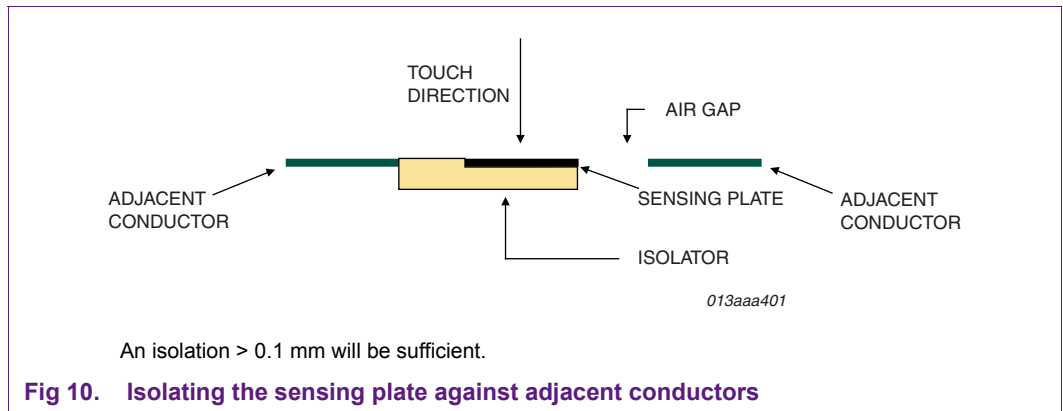
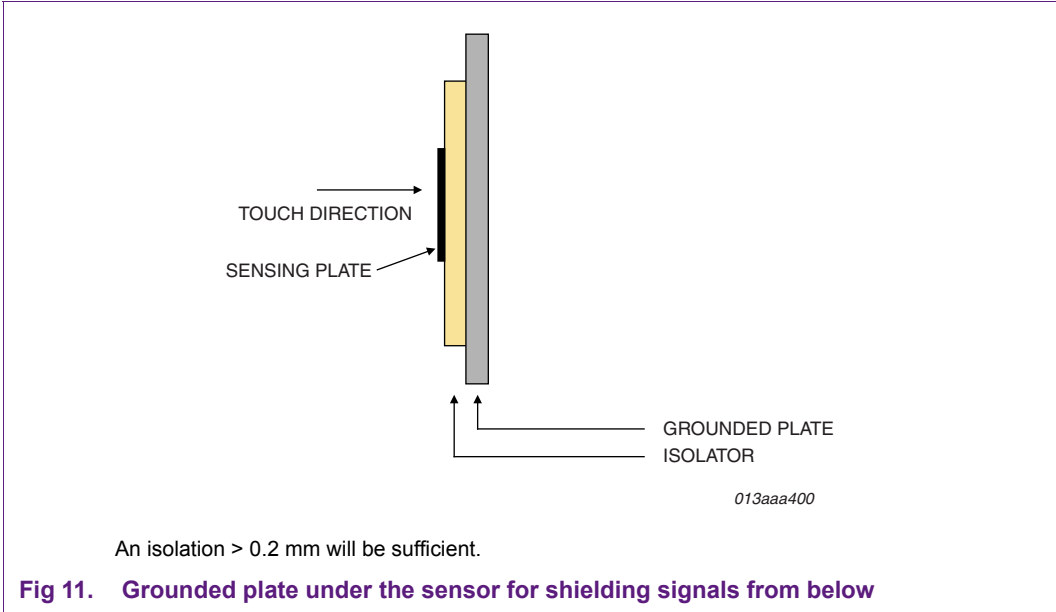

Fig 10. Isolating the sensing plate against adjacent conductors

A grounded plate placed underneath the sensor plate will shield signals from below, reduce any coupling, and give a defined sensor capacity, see [Figure 11](#). Such a ground plate can easily be realized using a double sided or multilayer PCB.

However, the grounded plate and the sensing plate are building a capacitor, which may reduce the sensitivity.



9. The capacitive compromise

A capacitive switch is always a compromise. A non self-calibrated capacitive device must be initially calibrated and will only function with one set of materials and over a particular distance. Dirt, humidity, and changes in temperature can impair and prevent the correct function.

The self-calibrated switch, PCF8883, adjusts itself continuously to the environment. It will only switch when the capacitance changes more than 63 times consecutively in one direction.

Very slow changes will be neutralized by the self-calibration. Extremely quick changes are not registered because the device never reaches the required number of changes to switch. In other words, the disturbance is digitally filtered out.

Therefore, the switch must be optimized for the typical application requirements. The big advantage is that such things as dirt, humidity, ice or damage to the electrode do not affect this device.

Our experience is that the user intuitively and quickly adapts to the device behavior without having to understand any of the technical details.

10. Legal information

10.1 Definitions

Draft — The document is a draft version only. The content is still under internal review and subject to formal approval, which may result in modifications or additions. NXP Semiconductors does not give any representations or warranties as to the accuracy or completeness of information included herein and shall have no liability for the consequences of use of such information.

10.2 Disclaimers

Limited warranty and liability — Information in this document is believed to be accurate and reliable. However, NXP Semiconductors does not give any representations or warranties, expressed or implied, as to the accuracy or completeness of such information and shall have no liability for the consequences of use of such information.

In no event shall NXP Semiconductors be liable for any indirect, incidental, punitive, special or consequential damages (including - without limitation - lost profits, lost savings, business interruption, costs related to the removal or replacement of any products or rework charges) whether or not such damages are based on tort (including negligence), warranty, breach of contract or any other legal theory.

Notwithstanding any damages that customer might incur for any reason whatsoever, NXP Semiconductors' aggregate and cumulative liability towards customer for the products described herein shall be limited in accordance with the *Terms and conditions of commercial sale* of NXP Semiconductors.

Right to make changes — NXP Semiconductors reserves the right to make changes to information published in this document, including without limitation specifications and product descriptions, at any time and without notice. This document supersedes and replaces all information supplied prior to the publication hereof.

Suitability for use — NXP Semiconductors products are not designed, authorized or warranted to be suitable for use in life support, life-critical or safety-critical systems or equipment, nor in applications where failure or malfunction of an NXP Semiconductors product can reasonably be expected to result in personal injury, death or severe property or environmental damage. NXP Semiconductors accepts no liability for inclusion and/or use of NXP Semiconductors products in such equipment or applications and therefore such inclusion and/or use is at the customer's own risk.

Applications — Applications that are described herein for any of these products are for illustrative purposes only. NXP Semiconductors makes no representation or warranty that such applications will be suitable for the specified use without further testing or modification.

Customers are responsible for the design and operation of their applications and products using NXP Semiconductors products, and NXP Semiconductors accepts no liability for any assistance with applications or customer product

design. It is customer's sole responsibility to determine whether the NXP Semiconductors product is suitable and fit for the customer's applications and products planned, as well as for the planned application and use of customer's third party customer(s). Customers should provide appropriate design and operating safeguards to minimize the risks associated with their applications and products.

NXP Semiconductors does not accept any liability related to any default, damage, costs or problem which is based on any weakness or default in the customer's applications or products, or the application or use by customer's third party customer(s). Customer is responsible for doing all necessary testing for the customer's applications and products using NXP Semiconductors products in order to avoid a default of the applications and the products or of the application or use by customer's third party customer(s). NXP does not accept any liability in this respect.

Export control — This document as well as the item(s) described herein may be subject to export control regulations. Export might require a prior authorization from national authorities.

Evaluation products — This product is provided on an "as is" and "with all faults" basis for evaluation purposes only. NXP Semiconductors, its affiliates and their suppliers expressly disclaim all warranties, whether express, implied or statutory, including but not limited to the implied warranties of non-infringement, merchantability and fitness for a particular purpose. The entire risk as to the quality, or arising out of the use or performance, of this product remains with customer.

In no event shall NXP Semiconductors, its affiliates or their suppliers be liable to customer for any special, indirect, consequential, punitive or incidental damages (including without limitation damages for loss of business, business interruption, loss of use, loss of data or information, and the like) arising out of the use of or inability to use the product, whether or not based on tort (including negligence), strict liability, breach of contract, breach of warranty or any other theory, even if advised of the possibility of such damages.

Notwithstanding any damages that customer might incur for any reason whatsoever (including without limitation, all damages referenced above and all direct or general damages), the entire liability of NXP Semiconductors, its affiliates and their suppliers and customer's exclusive remedy for all of the foregoing shall be limited to actual damages incurred by customer based on reasonable reliance up to the greater of the amount actually paid by customer for the product or five dollars (US\$5.00). The foregoing limitations, exclusions and disclaimers shall apply to the maximum extent permitted by applicable law, even if any remedy fails of its essential purpose.

10.3 Trademarks

Notice: All referenced brands, product names, service names and trademarks are the property of their respective owners.

11. Contents

1	Introduction	3
2	Dimensioning of R_C, C_{CPC}, and C_{CLIN}	4
2.1	R_C	4
2.2	C_{CPC}	4
2.3	C_{CLIN}	5
3	Sensitivity and capacitance changes	6
3.1	Capacitance changes	7
4	Approach speed and dynamics	8
5	Influence of the size and form of the capacitor plates (electrodes)	9
6	Influence of thickness and nature of the dielectric	11
6.1	Air gap	11
6.2	Conductive foam	12
7	Plate (electrode) orientation	14
8	Electrical environment	15
9	The capacitive compromise	17
10	Legal information	18
10.1	Definitions	18
10.2	Disclaimers	18
10.3	Trademarks	18
11	Contents	19

Please be aware that important notices concerning this document and the product(s) described herein, have been included in section 'Legal information'.

© NXP B.V. 2010.

All rights reserved.

For more information, please visit: <http://www.nxp.com>

For sales office addresses, please send an email to: salesaddresses@nxp.com

Date of release: 8 September 2010

Document identifier: AN10832